

1-12 t

ROBUST. COMPATIBLE. RELIABLE.

Mechanical and hydraulic quickcouplers and attachments for mini and compact excavators.



AN IDEA THAT HAS CONQUERED THE MARKET.
AND IT ENSURES YOU INVESTMENT SECURITY, FLEXIBILITY AND PRODUCTIVITY.

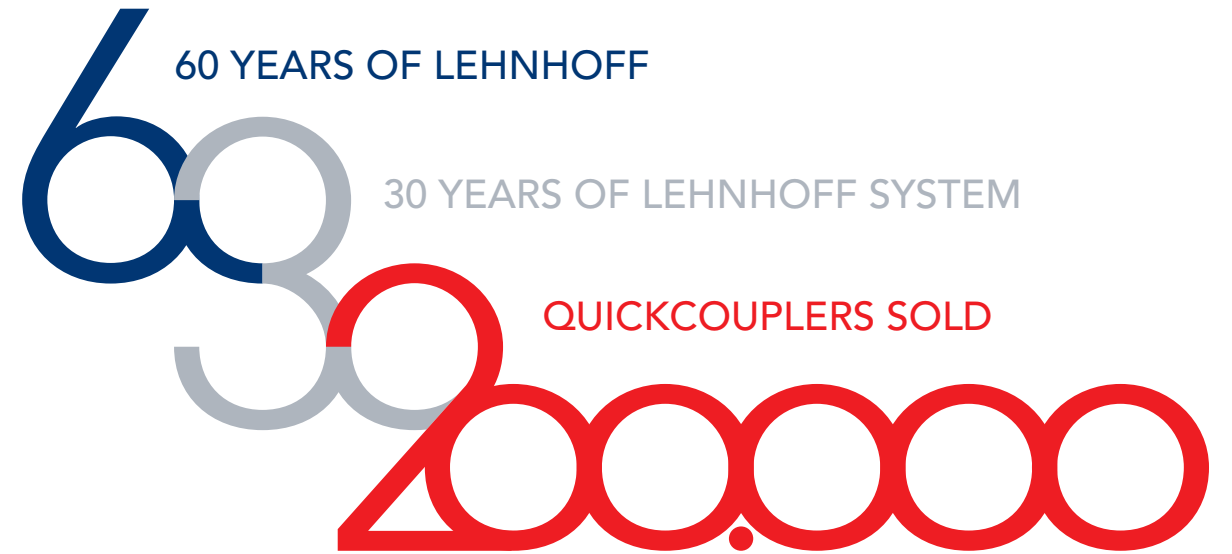

MARKET-LEADING SYSTEM

The Lehnhoff system of mechanical and hydraulic quickcouplers was introduced 30 years ago. quick couplers has since conquered the market. Thanks to the always up-to-date database kinematics data of all excavator types on the market, the retention of the original bucket the original bucket in and out tipping angles is always guaranteed. A real plus for Lehnhoff customers.

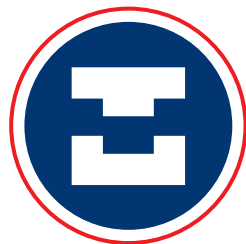

UNIVERSAL STANDARD

With the quickcoupler on the excavator and the adapter on the attachment, Lehnhoff has created a universal interface that allows the use of all attachments on different excavator makes and that has now been installed in over 200,000 excavators.



BETTER MACHINE UTILIZATION

due to more diverse application possibilities. Tool changes - even with short work cycles - increase efficiency.



INCREASED PRODUCTIVITY

through faster equipment changes and more diverse applications that speed up the completion of construction projects and create time savings for other projects.



HIGHER CHANCE OF SURCHARGE

as versatile excavators are increasingly being included as a criterion in the evaluation of public tenders, because they promise more economical project execution due to the more efficient use of the excavator and the personnel. Added to this is the expansion of your company's range of services. Work cycles increase efficiency.



INCREASED LONGEVITY

thanks to certified manufacturing process to ensure accuracy of fit and function. Longevity is also increased by protecting the machine and attachments, as the tools are always used as intended, resulting in lower maintenance requirements.



CON-

Page 4

Lehnhoff quickcouplers and adapter systems

Page 5

Safety standard Double Lock

Page 6

Adapters from Lehnhoff

Page 7

Symlock® from Lehnhoff

Page 8

Powertilt from Lehnhoff

Page 10

Quickcouplers for micro and mini excavators 1- 6 t

Page 14

Quickcoupler for compact excavators 6 - 12 t

Page 17

Attachments for Excavators 1- 12 t

LEHNHOFF QUICKCOUPLERS AND ADAPTER SYSTEMS.

STANDARD AND BENCHMARK IN THE MINI AND COMPACT EXCAVATOR CLASS.

QUICK COUPLER ADAPTER SYSTEM WITH FIXED, BACKLASH-FREE CONNECTION AND AUTOMATIC ADJUSTMENT

- Long service life thanks to robust cast steel housing, all contact surfaces precisely CNC-machined
- Reliable and durable: Automatic adjustment for backlash-free connection of quickcoupler and adapter
- Minimal loss of tensile strength due to low overall height
- Long service life and low maintenance due to sealed locking mechanism
- Available for all excavator brands and all suspensions



Firmly connected: Lehmatic quickcoupler and adapter



All Lehmatic quickcouplers are optionally available with load hooks (3 - 5 t permissible load)

Locking mechanism/ -hydraulics protected in sealed housing

Precisely machined coupling claws

Adapter with locking plate and coupling shaft

THE NEW WORK SAFETY STANDARD DOUBLE LOCK.

FOR ALL HYDRAULIC QUICKCOUPLERS (HS).

The standard Double Lock safety mechanism prevents the attachment from falling in the event of an incorrect locking procedure.

- BG-BAU-eligible
- EuroTest certified
- Exceeds all safety standards (EN 474, ISO 13031)



CONVINCING SAFETY FEATURES OF THE CERTIFIED DOUBLE LOCK

- Drop safety device prevents the attachment from falling down in case of incorrect locking.
- Safety claw positively encloses the pick-up shaft immediately after the lock is actuated and prevents complete loosening of the attachment in any position.
- New indicator pins provide information on the position of the locking pins at all times.
- Wear-resistant thanks to robust construction.

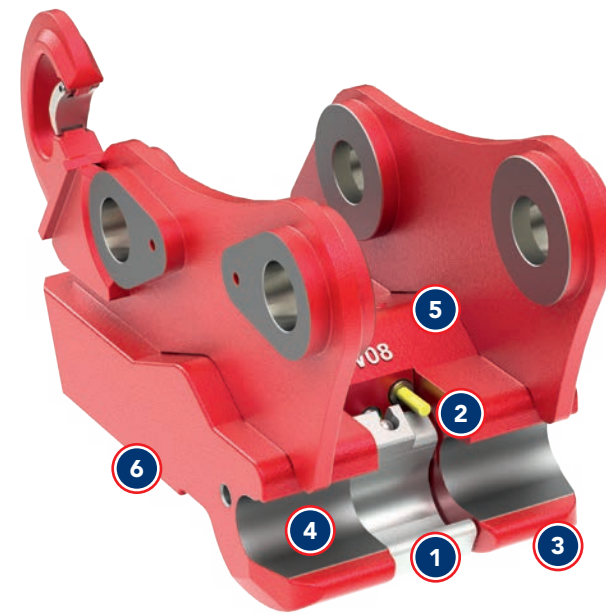

FAST AND CONVENIENT ATTACHMENT CHANGE

Lehnhoff quickchange systems enable the excavator operator to change tools within 1 minute. Without the help of a colleague. When using a hydraulic control circuit, even conveniently from the cab.



- 1 Newly developed locking mechanism with safety claw (Double Lock)
- 2 Optical locking indication via indicator pin
- 3 Low wear thanks to larger surface on the widened pick-up claws
- 4 Easier tool pick-up due to optimized claw geometry
- 5 New: Emergency unlocking
- 6 Compatible with existing Lehnhoff adapters

DOUBLE LOCK – FUNCTIONALITY



CREATE FOR FOR ALL BRANDS CONNECTIONS: THE LEHNHOFF ADAPTERS.



SO ALL ATTACHMENTS OF ALL BRANDS ARE GUARANTEED TO FIT

No matter which attachment of which brand you want to connect to your excavator: Lehnhoff adapters bring them together. Lehnhoff offers adapted Lehnhoff adapters for all common tools and attachments.

- **Front:** Pick-up shaft for the pick-up claws of the quickcoupler
- **Back:** High-precision locking plate with the two characteristic holes



Adapter frame for backhoe bucket and bucket conversion

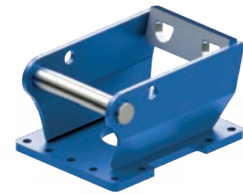

Screw-on adapter for special drilling patterns/hose routing



Welding adapter for welding to attachments

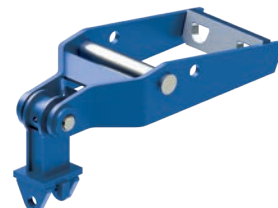

Gripper adapter for holding grippers of all types

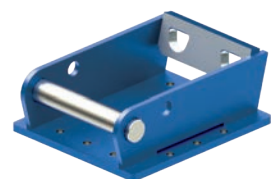

Screw adapter for demolition tools like hydraulic hammers, shears etc..



Special adapters, e.g. for load hooks

THE TRANSFORMATION ARTIST: THE SYMLOCK® ADAPTER FROM LEHNHOFF.

THE SYMLOCK® ADAPTER QUICKLY TURNS A BACKHOE BUCKET INTO A HIGH BUCKET

With the Symlock® adapter, you can turn a backhoe bucket into a high bucket in a flash and vice versa - with a 180° rotation of the bucket. The characteristic latch plate and pick-up shaft on the adapter have been replaced by 2 symmetrically arranged pick-up shafts with flats for the latch surface and latch pin of the quick coupler. These allow both the conventional position in the adapter and a 180° rotated seat.

- All advantages of the Lehnhoff quickcoupler system are retained
- **Ideal for:**
 - limited range
 - material intake
 - backfilling in front of walls
 - excavation
 - obstacles



Backhoe bucket with Symlock® adapter



Ditch cleaning bucket with Symlock®-adapter



Symlock®-adapter allows for backhoe bucket use ...

... as well as shovel bucket use with a 180°-rotation



Original Symlock®:
Der Standard mit dem Doppelnutzen – symmetrisch, praktisch, herausragend.



POWERTILT QUICKCOUPLERS FOR MS AND HS. WORKING IN LOT WITH REAL 180°-WORKING AREA.



Additional degrees of freedom:
up to $2 \times 90^\circ$ for all mini and
compact excavators.

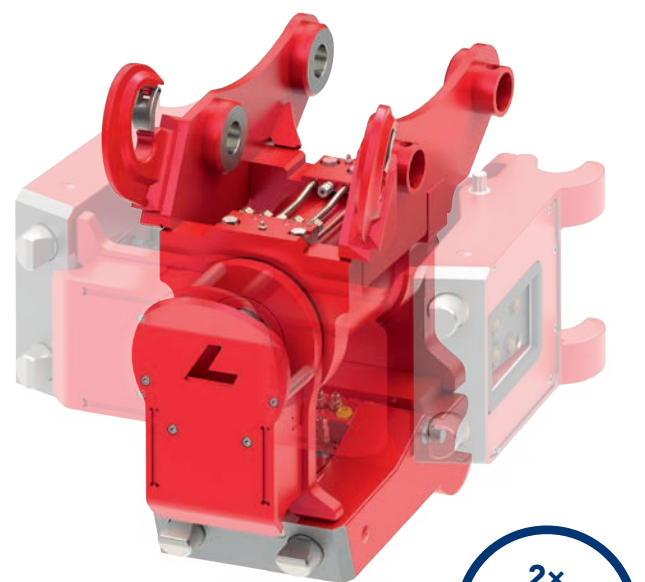

QUICKCOUPLER WITH TILTING MOTOR

- Combines all the advantages of a quickcoupler and a tilting motor.
- Works versatile with attachments and digging buckets of all kinds and can attach to narrow buckets in particular
- The ideal solution e.g. for work in sewer construction or targeted material backfilling

ADVANTAGES

- Enormous working range: Up to $2 \times 90^\circ$ tilting angle on both sides (180°)
- Including rotary pass-through for hydraulics (Powertilt)
- **Tilting** motor sealed and protected against damage
- High holding forces and robust design for the toughest applications
- Can be combined with all Lehnhoff quickcouplers
- On the excavator side optionally with direct attachment or quickcoupler attachment

QUICKCOUPLER WITH POWERTILT MOTOR

Large tilting angle $2 \times 90^\circ$,
high holding forces,
low maintenance

Rotating pass-through for
2 hydraulic lines.
Simplest installation,
compact design, protected
protected hydraulic line
due to omission of
hose routing over
the axis of rotation

One line used for opening
of the quickcoupler
(HS03H)

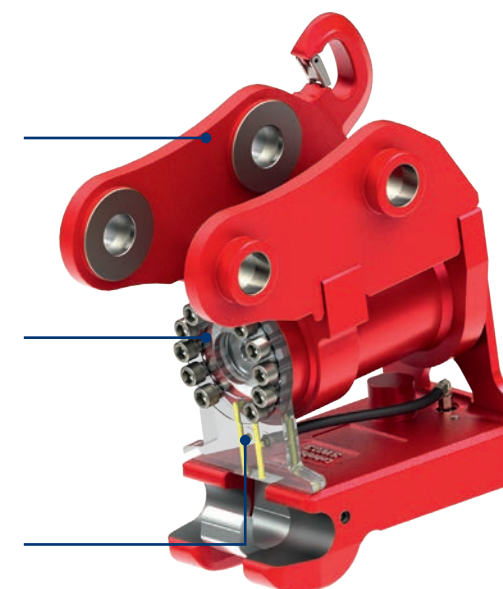

Tilt quickcoupler with direct attachment
on the excavator side



Tilt quickcoupler with quickcoupler suspension
on excavator side (sandwich)

1-6 t

QUICK COUPLER FOR MICRO AND MINI EXCAVATORS FROM 1 TO 6 TONS.

THE MS01 AND MS03 MECHANICAL QUICKCOUPLERS FOR EXCAVATORS 1 TO 6 TONS. ATTACHMENT CHANGE IN NO TIME.

MECHANICAL QUICK COUPLER (MS) WITH NEW 180° LOCKING MECHANISM

- Quick, easy and safe locking with socket wrench and only 180° shift travel
- No need to set or readjust the connection
- Self-locking dead center locking mechanism, sealed in housing
- Optionally available with load hook (2t/3t)

Patented quick-locking mechanism with safe dead center mechanism in ultra-compact mini housing.

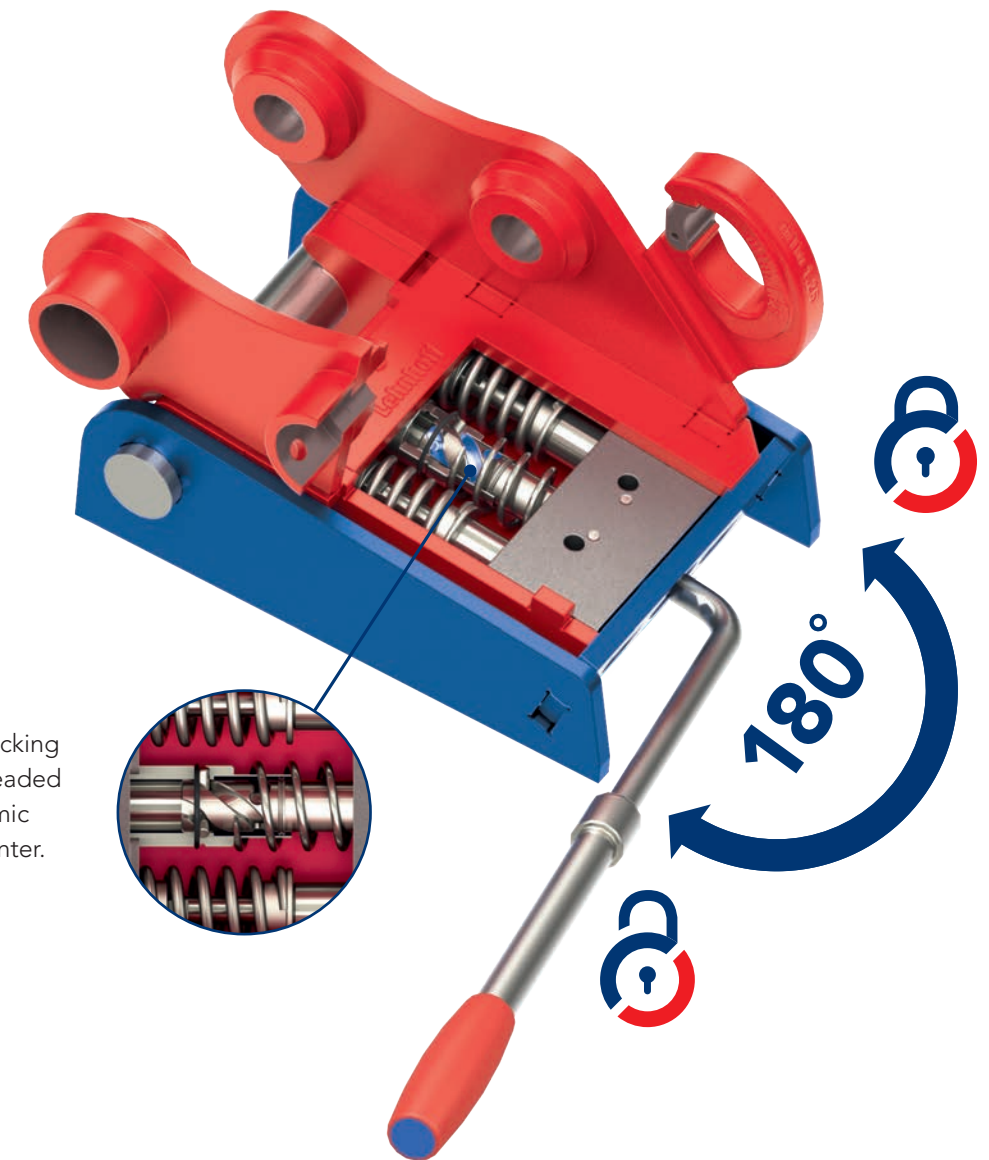

Simple and safe locking due to 3-flight threaded spindle with dynamic pitch and dead center.

THE HYDRAULIC QUICKCOUPLERS FOR EXCAVATORS 1 TO 6 TONS. CONVENIENT CHANGING FROM THE DRIVER'S CAB.

HYDRAULIC QUICKCOUPLERS (HS) FOR EXCAVATORS 1-6 T (HS01/HS03)

- Convenient changing from the driver's cab
- Operator activates the control valve via unlockable toggle switch and locks/unlocks the quickcoupler at the push of a button
- The quickcoupler is always locked securely and backlash-free by permanent spring pressure application
- Unlocking hydraulically via single-acting cylinder
- Optional safety assistance system Lehnhoff Safety Control (LSC) - only one line required for unlocking

Locking and unlocking from the cabin with only one hydraulic line and 2-fold safety.

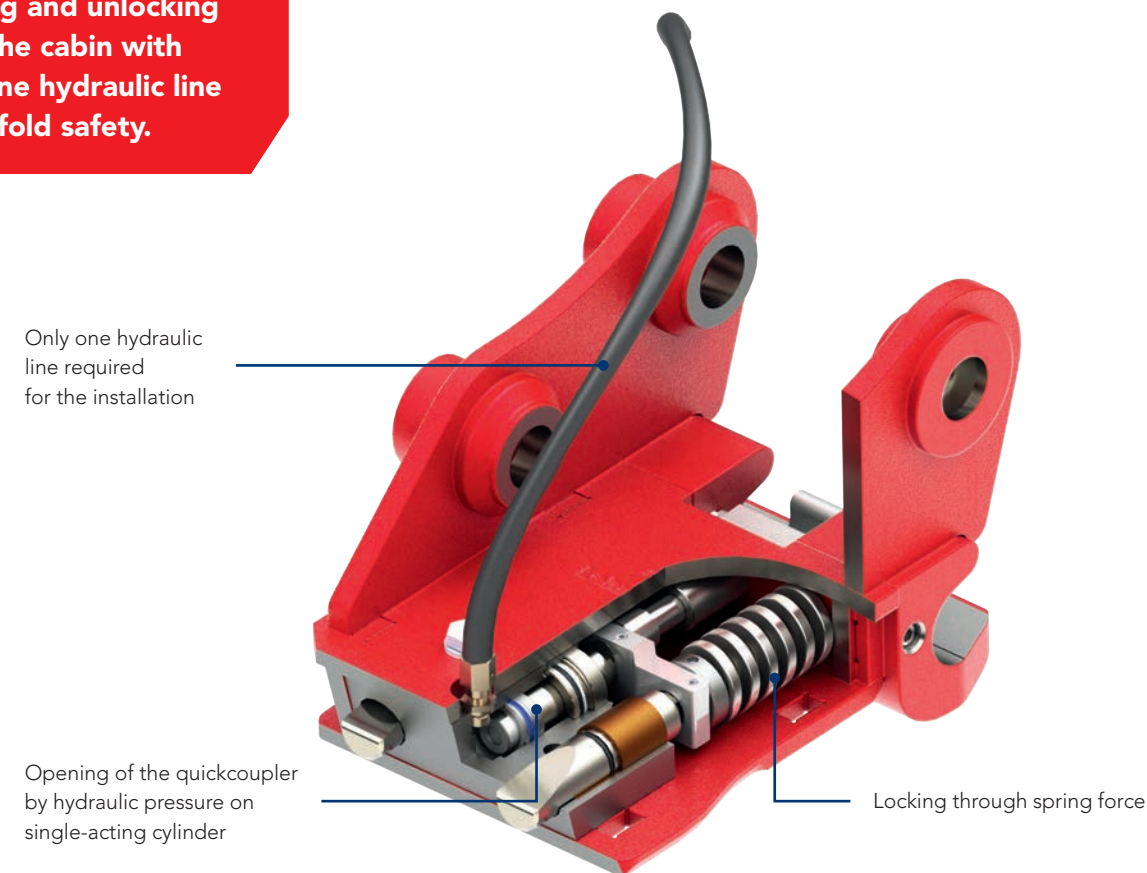

HYDRO-BLOCK-QUICKCOUPLER (HSH)

- Convenient changing from the driver's cab
- Always secure locking due to permanent spring pressure - with additional hydraulic locking of the locking bolts for stronger mini-excavators from 4.8 t and heavy-duty tools such as hydraulic hammers
- Unlocking hydraulically via single-acting cylinder
- Optional safety assistance system Lehnhoff Safety Control (LSC)

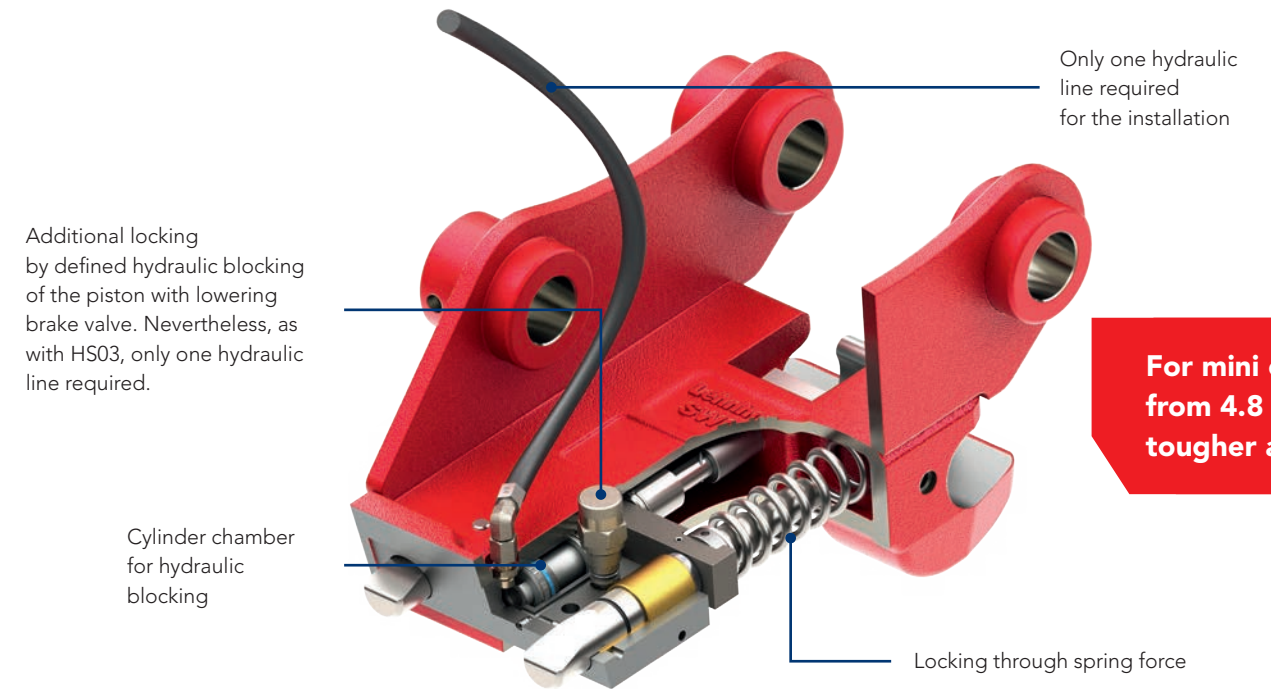

For mini excavators from 4.8 t and tougher applications.

For coupling hydraulic attachments from the cabin: **HS03V**

**FULLY HYDRAULISCH.
FULLY AUTOMATIC.
FULLY CONVINCING.**

More at voll.lehnhoff.de



6-12 t

QUICK COUPLER FOR COMPACT EXCAVATORS FROM 6 TO 12 TONS.

THE MS08 MECHANICAL QUICKCOUPLERS FOR EXCAVATORS 6 TO 12 TONS. ATTACHMENT CHANGE IN NO TIME.

MECHANICAL QUICKCOUPLERS (MS)

- Simple, fast and secure locking by hand using a socket wrench
- Long service life of the quickcoupler system due to the automatic adjustment in the adapter
- High functional safety due to locking via dead center
- Long service life and low maintenance due to sealed locking mechanism
- Optionally with 1 load hook



Proven, solid and simple 120° locking via toggle lever principle.

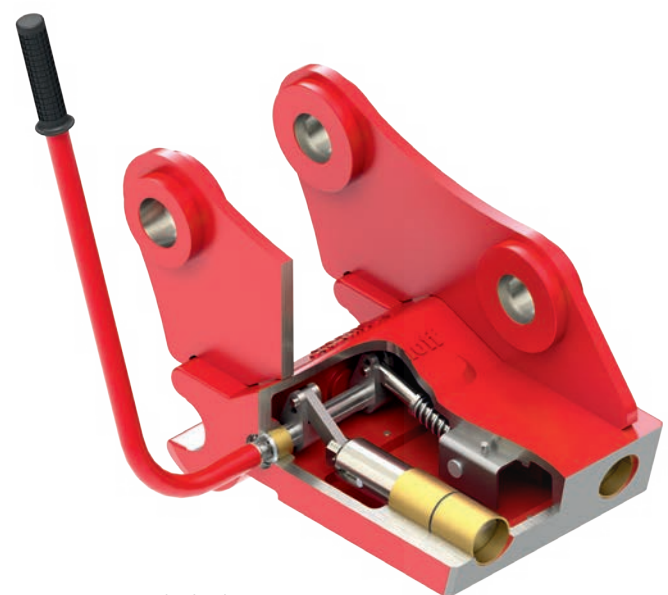
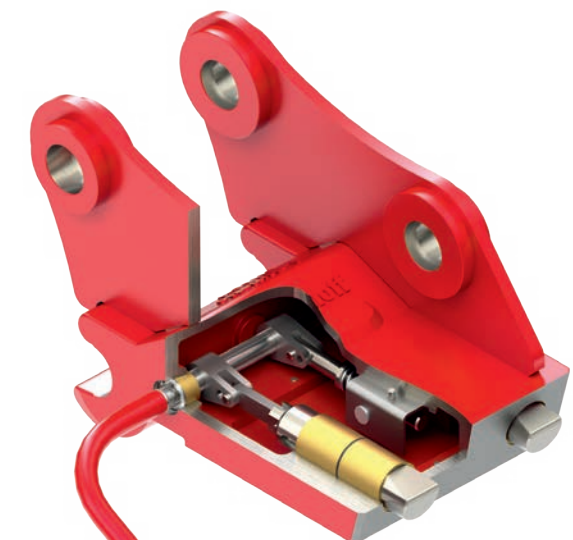

Socket wrench turned 120°, quickcoupler securely locked over dead center

Unlocked:
Locking Pins
Retracted



6-12 t

THE HS08 HYDRAULIC QUICK COUPLERS FOR EXCAVATORS 6 TO 12 TONS. CONVENIENT CHANGING FROM THE DRIVER'S CAB.

HYDRAULISCHER SCHNELLWECHSLER (HS)

- Convenient changing from the driver's cab
- Driver activates the control valve via unlockable toggle switch and locks/unlocks the quickcoupler at the push of a button
- Always safe holding position of the lock due to constant pressurization and integrated safety valve on the hydraulic cylinder
- High functional safety due to sealed locking mechanism/hydraulics, optional safety assistance system Lehnhoff Safety Control (LSC)
- 2 hydraulic lines required for locking/unlocking



Double-acting hydraulic locking and unlocking function with safety valve and Double Lock.

Visual interlock indicator, visible from driver's cab, indicator pin extended

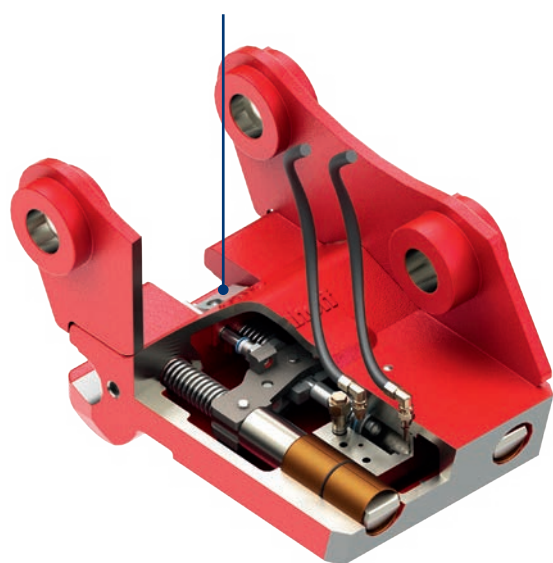

Unlocked: Locking Pins Retracted

Visual interlock indicator, visible from driver's cab, indicator pin retracted

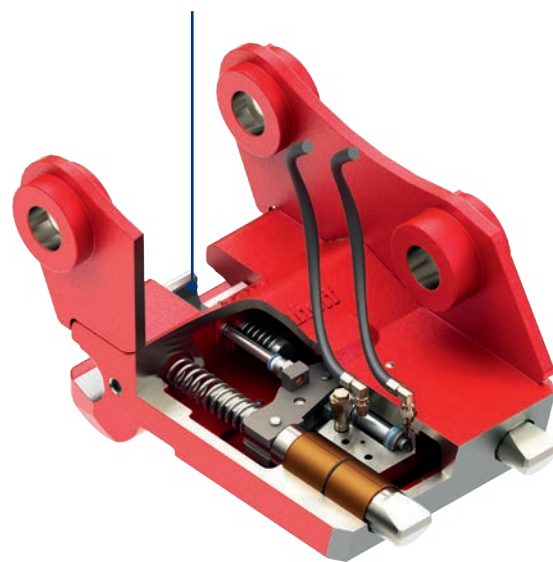

Safely locked: Hydraulic cylinder with integrated safety valve and constant pressurization

COMPATIBLE AND
FROM ONE SOURCE!
THE ATTACHMENTS OF
THE MARKET LEADER.



FROM EXCAVATION TO LEVELING. THE ROBUST AND FLEXIBLE BUCKETS FROM LEHNHOFF.



MINI BASIC BUCKET (MBL)

The MBL standard quality backhoe bucket is ideal for all common light to medium duty applications such as digging, grading, backfilling and loading.

- Good filling properties and easy emptying due to LH double-conical design
- Bottom inside made of S355 steel
- Blade made from 400-HB steel
- Screwed fork teeth
- Optionally with Lehnhoff or Symlock® adapter
- Bucket safety tab included

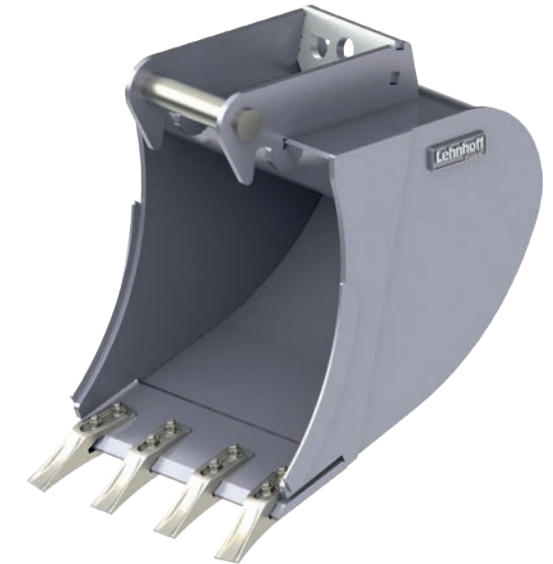

BASIC BACKHOE BUCKET FOR MINI EXCAVATORS 1 – 6 T

	MBL 1		MBL 2		MBL 3		MBL 4		MBL 6	
excavator	1–1,5 t		1,6–2,5 t		2,6–3,5 t		3,6–4,9 t		5–6 t	
Cutting width	SAE	KG	SAE	KG	SAE	KG	SAE	KG	SAE	KG
250 / 3 Z	26	38								
300 / 3 Z	30	39	40	49	60	74	70	80	80	83
400 / 3 Z	40	49	60	57	70	84	100	90	120	85
500 / 3 Z	50	53	80	65	100	95	130	104	140	106
600 / 4 Z	60	62	97	72	130	108	160	114	180	118
800 / 5 Z					180	129	230	139	250	144
1000 / 5 Z									320	170

Cutting width (mm), Z = teeth, SAE = content (l), KG = weight (kg)

MBL S WITH EXTENDED CUTTING EDGE / WITHOUT TEETH

The MBL S Basic backhoe buckets in standard quality have no teeth, but a cutting edge that is extended by approx. the length of the teeth. Ideal for all light to medium-duty cable and duct work.

- Good filling properties and easy emptying due to LH double-conical design
- Bottom inside made of S355 steel
- Extended blade made from 400-HB steel, approx. 10 % more content compared to MBL
- With Symlock® adapter
- Bucket safety tab included



MBL S CUTTING EDGE / WITHOUT TEETH FOR MINI EXCAVATORS 1 – 6 T

	MBL 1 S		MBL 2 S		MBL 3 S		MBL 4 S		MBL 6 S	
excavator	1–1,5 t		1,6–2,5 t		2,6–3,5 t		3,6–4,9 t		5–6 t	
Cutting width	SAE	KG	SAE	KG	SAE	KG	SAE	KG	SAE	KG
250	29	33								
300	33	36	44	43	62	71	70	80	88	84
400	44	43	66	51	83	82	100	90	132	97
500	55	49	88	58	110	94	130	104	154	110
600	66	55	107	66	140	106	160	114	198	123
800					198	130	230	139	275	149
1000									352	175

Cutting width (mm), SAE = content (l), KG = weight (kg)

SHOWING TEETH ON THE CONSTRUCTION SITE. THE PREMIUM BACKHOE AND SORTING BUCKETS FROM LEHNHOFF.

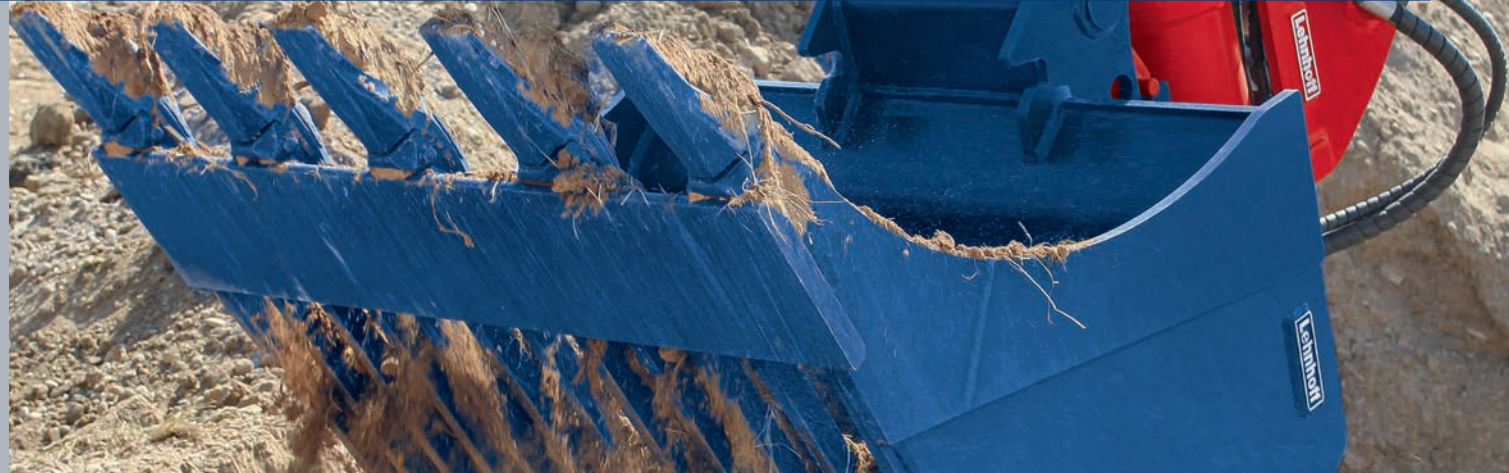

SORTING BUCKETS MSL1 TO MSL6, CSL5, CSL10, CSL12

For separating all types of coarse and fine material.
MSL version for mini-excavators with plasma-fired bottom,
CSL version with bottom made of solid rectangular lattice
bars..

- Robust bucket design in the versions for mini excavators (MSL) and compact excavators
- CSL: bottom made of solid rectangular lattice bars 30 x 20 mm, bar spacing 60 mm
- MSL: Optionally burnt-out perforated floor made of 400 HB steel, hole spacing approx. 50 mm or floor made of solid rectangular lattice bars

SORTING BUCKETS FOR MINI EXCAVATORS UP TO 6 T

	MSL 1		MSL 2		MSL 3		MSL 4		MSL 6	
excavator	1-1,9 t		1-1,9 t		2,6-3,5 t		3,6-5 t		5,1-6 t	
cutting width	SAE	KG	SAE	KG	SAE	KG	SAE	KG	SAE	KG
600 / 4 Z	60	58	100	65	127	90	162	100		
800 / 5 Z							800	120	250	125
1000 / 5 Z									320	143

cutting width (mm), SAE = content (l), KG = weight (kg)

You have the choice:
MSL with either plasma-fired base or
solid rectangular grid bars.

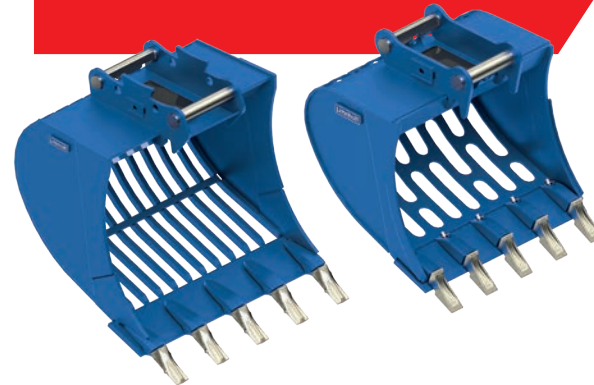

SORTING BUCKETS FOR COMPACT EXCAVATORS 6 TO 12 T

	CSL 5		CSL 10		CSL 12	
excavator	6,1-8 t		8,1-10 t		10,1-12 t	
cutting width	SAE	KG	SAE	KG	SAE	KG
800 / 5 Z	300	245				
1000 / 5 Z			460	295		
1200 / 6 Z					620	355

PREMIUM BACKHOE BUCKETS MTL1 TO MTL6, CTL5, CTL 10, CTL12

Like the large buckets from Lehnhoff, the MTL and CTL backhoe buckets for mini and compact excavators meet the highest quality standards and are also designed for the toughest applications.

- Highest quality materials and unique weld quality for highest efficiency and durability
- Optimum filling and draining properties enable reduced fuel consumption
- Also available as version without teeth with advanced cutting edge

New generation:
With new Lehnhoff premium GetS-harp tooth system for 15 % better penetration and less wear.



PREMIUM BACKHOE BUCKETS FOR MINI EXCAVATORS UP TO 6 T

	MTL 1		MTL 2		MTL 3		MTL 4		MTL 6	
excavator	1-1,5 t		1,6-2,5 t		2,6-3,5 t		3,6-4,9 t		5-6 t	
cutting width	SAE	KG	SAE	KG	SAE	KG	SAE	KG	SAE	KG
220 / 2 Z	23	30								
250 / 3 Z	26	35								
300 / 3 Z	30	38	40	47	56	68	66	74	80	78
400 / 3 Z	40	42	60	58	75	78	96	80	120	87
500 / 3 Z	50	46	80	66	100	90	130	92	140	105
600 / 4 Z	60	54	97	71	127	97	162	99	180	109
800 / 5 Z					180	116	230	124	250	131
1000 / 5 Z									320	150
tooth system	404F		404F		400F		400F		400F	

cutting width (mm), Z = teeth, SAE = content (l), KG = weight (kg)

PREMIUM BACKHOE BUCKETS FOR COMPACT EXCAVATORS 6 TO 12 T

	CTL 5		CTL 10		CTL 12	
excavator	6,1-8 t		8,1-10 t		10,1-12 t	
cutting width	SAE	KG	SAE	KG	SAE	KG
400 / 3 Z	130	162	155	163	170	170
500 / 3 Z	170	174	200	178	225	184
600 / 4 Z	210	194	255	200	280	220
800 / 5 Z	300	226	360	236	395	245
900 / 5 Z	340	252	410	255		
1000 / 5 Z	380	280	460	285	510	310
1200 / 5 Z					620	370
tooth system	411F		U20S		U20S	

MTL S BLADE WITHOUT TEETH FOR MINI EXCAVATORS UP TO 6 T

	MTL 1 S		MTL 2 S		MTL 3 S		MTL 4 S		MTL 6 S	
excavator	1-1,5 t		1,6-2,5 t		2,6-3,5 t		3,6-4,9 t		5-6 t	
cutting width	SAE	KG	SAE	KG	SAE	KG	SAE	KG	SAE	KG
220	25	29								
250	29	31								
300	33	34	44	42	62	63	73	73	88	79
400	44	40	66	49	83	72	106	84	132	91
500	55	46	88	56	110	81	143	95	154	102
600	66	51	107	64	140	91	178	105	198	113
800					198	109	253	127	275	135
1000									352	157

SAE = content (l), KG = weight (kg)

CTL S BLADE WITHOUT TEETH FOR COMPACT EXCAVATORS 6 TO 12 T

	CTL 5 S		CTL 10 S	
excavator	6,1-8 t		8,1-10 t	
cutting width	SAE	KG	SAE	KG
300	100	115		
400	142	135	175	150
500	185	150	220	165
600	230	165	280	185
800	325	200	400	220
900	370	215	450	235
1000	415	230	510	245

THE UNIVERSAL TILTING BUCKETS MU4, CU5, CU10, CU12

Lehnhoff's universal tilting buckets for mini and compact excavators are ideal for material excavation as well as slope and grading work.

- Large tilting angle of $2 \times 45^\circ$
- Good filling properties and easy emptying due to LH double-conical design (swing bucket with deep bucket-like shape)
- Blades and side blades made of Lehborit 5000 (500 HB)
- Smooth and sturdy bottom (400 HB)
- Optionally with Lehmatic, Symlock® or Variolock adapter
- Available with hydraulic cylinder (H), hydraulic rotary motor (M) or rigid version



Optional: Also available with robust low-maintenance hydraulic motor.

SCHWENKLÖFFEL FÜR MINIBAGGER 1 BIS 6 T

	MU 4 GH		MU 4 GM	
excavator	3,6-6 t		3,6-6 t	
cutting width	SAE	KG	SAE	KG
1000	200	170	200	255
1200	230	190	230	285

cutting width (mm), SAE = content (l), KG = weight (kg)

SCHWENKLÖFFEL FÜR KOMPAKT BAGGER 6 BIS 12 T

	CU 5 GH		CU 5 GM		CU 10 GH		CU 10 GM		CU 12 GH		CU 12 GM	
excavator	6,1-8 t		6,1-8 t		8,1-10 t		8,1-10 t		10,1-12 t		10,1-12 t	
cutting width	SAE	KG	SAE	KG	SAE	KG	SAE	KG	SAE	KG	SAE	KG
1200	267	343	267	446	420	397	350	500				
1400	318	398	318	488	500	455	400	545	560	500	560	510

THE DITCH CLEANING BUCKETS MG09, MG1, MG2, MG4, MG6, CG5, CG10

- Large tilting angle of $2 \times 45^\circ$
- Long bottom, optimal for profile work
- Round sides for perfect digging properties
- Blades and side blades made of Lehborit 5000 (500 HB)
- 1 hydraulic cylinder, > 5 t excavator incl. 2 hydraulic cylinders for optimum force distribution
- CG-Tilting bucket also available with rotary motor (M)
- Also available in rigid version

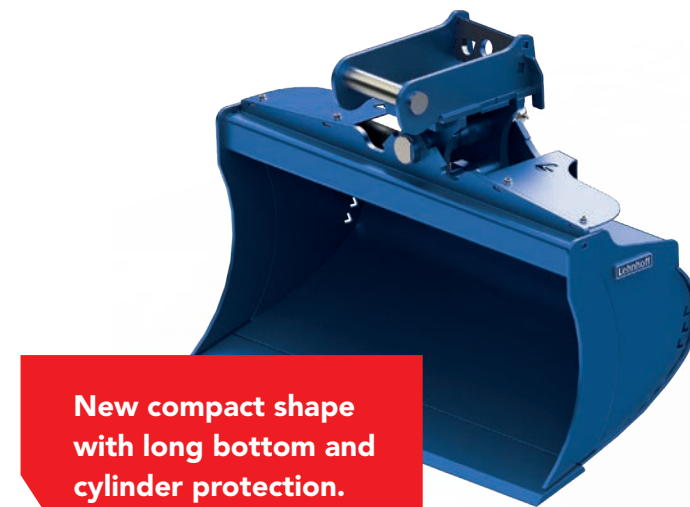

New compact shape with long bottom and cylinder protection.

NEW: DITCH CLEANING BUCKETS FOR MINI EXCAVATORS 0,5 TO 6 T

	MG 09		MG 1		MG 2		MG 4		MG 6	
excavator	0,5-0,9 t		1-1,9 t		2-2,5 t		2,6-5 t		5,1-6 t	
cutting width	SAE	KG	SAE	KG	SAE	KG	SAE	KG	SAE	KG
700	35	68	200	255						
850			70	111						
1000			80	127	92	136	150	172		
1200			100	143	117	154	180	192	190	210
1400							208	214	220	231
1500							220	222		
1600									250	251

cutting width (mm), SAE = content (l), KG = weight (kg)

DITCH CLEANING BUCKETS FOR COMPACT EXCAVATORS 6 TO 12 T

	CG 5		CG 10	
excavator	6,1-8 t		8,1-10 t	
cutting width	SAE	KG	SAE	KG
1500	280	328		
1600	300	340	380	350
1800			420	390

GRADING BUCKET - IDEAL FOR USE ON ROTATORS / TILTROTATORS MP4, CP5, CP10

With a far-forward blade, double-conical side walls and optimized trapezoidal design, Lehnhoff grading buckets are ideal for grading and undermining work.

- Chamfered corners
- Long flat bottom and LH double conical design
- Thus optimum penetration behavior and fuel economy
- Good emptying



Good clearance!
The new grading bucket

GRADING BUCKET FOR MINI EXCAVATORS 1 BIS 6 T

	MP 4	
excavator	2,6-5 t	
cutting width	SAE	KG
1000	200	170
1200	230	190

GRADING BUCKET FOR COMPACT EXCAVATORS 6 BIS 12 T

	CP 5		CP 10	
excavator	6,1-8 t		8,1-10 t	
cutting width	SAE	KG	SAE	KG
1000	200	255		
1200	230	285	290	275

cutting width (mm), SAE = content (l), KG = weight (kg)



GRIPPING EVEN MORE POWERFULLY. THE SORTING GRABS FROM LEHNHOFF.



Big mouth with firm bite:
Large opening width
and high closing force with
low wear

DEMOLITION AND SORTING GRABS MSG30, MSG60, CSG100, CSG120

The Lehnhoff demolition and sorting grabs are suitable for sorting, loading, setting stones and grabbing wood. They feature a very robust and at the same time compact design as well as large opening widths and shell volumes and convince by high closing, turning and holding forces.

- Rotation angle 360° endless
- Robust construction for long service life
- Interchangeable screw-on blade
- Maintenance-friendly: All lubrication points accessible in one position
- Gripper shells closed or with bars available on request
- Including Lehmatic screw-on adapter
- Optionally with Variolock adapter, direct suspension or adapter for all common quick couplers



SORTING GRABS FOR MINI EXCAVATORS 1 TO 6 T

	MSG 30	MSG 60
excavator	2,6–3,5 t	5–6 t
Opening dimensions (mm)	1137	1350
Shell width (mm)	650	650
Height without adapter	703	975
Closing force (kN)	12	26
Weight (kg)	210	425
Content (l)	100	140
Operating pressure (bar)	320	320
Operating pressure Rotation (bar)	120	120
Oil flow (l/min)	35	50
Oil flow Rotation (l/min)	20	20

SORTING GRABS FOR COMPACT EXCAVATORS 6 TO 12 T

	CSG 100	CSG 120
excavator	8–10 t	10,1–12 t
Opening dimensions (mm)	1350	1750
Shell width (mm)	650	800
Height without adapter	975	1380
Closing force (kN)	26	41
Weight (kg)	425	870
Content (l)	140	325
Operating pressure (bar)	320	320
Operating pressure Rotation (bar)	120	140
Oil flow (l/min)	50	80
Oil flow Rotation (l/min)	20	40

ON THE NAIL. THE RIGID ATTACHMENTS FROM LEHNHOFF.

RIPPER TEETH MRZ1, MRZ3, MRZ6, CRZ8

The bionically optimized ripper teeth from Lehnhoff stand for efficiency and stability when ripping and loosening rock, stone and soil. With welded-on tooth tip. And with Lehmatic adapter. Ideal for:

- loosening of hard or frozen soils
- demolition work
- loosening rock and stone
- breaking up road surfaces and concrete slabs
- clearing work

Learned from nature:
Bionically optimized design for particularly high stability (middle claw anteater).



BIONIC RIPPER TEETH FOR MINI EXCAVATORS 1 TO 6 T

	MRZ 1	MRZ 3	MRZ 6
excavator	1,8 t	1,8-3,5 t	3,6-6 t
adapter size	SW01	SW03	SW03
tooth radius (mm)	500	550	650
weight (kg)	32	60	63

BIONIC RIPPER TEETH FOR COMPACT EXCAVATORS 6 TO 12 T

	CRZ 8
excavator	6-12 t
adapter size	SW08
tooth radius (mm)	750
weight (kg)	124

CLEARING RAKE MRR10, MRR60, CRR80

The Lehnhoff clearing rake was developed for forest and landscape maintenance as well as clearing small rootstocks. Clearing material such as branches, tree tops and small rootstocks are swept up from the ground. The four-pronged clearing rake can be attached to all common mini and midi excavators in no time at all using the Lehnhoff SW attachment. The bionic geometry (ripper tooth-like shape) ensures perfect force distribution and leads to optimal penetration of the soil.

- bionic geometry
- robust design
- durable - due to perfectly coordinated use of materials (HB 400/HB 500)
- Symlock® adapter included

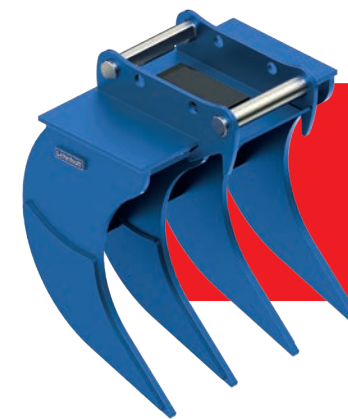

The king of rakes:
Quadruple sharp and always available from stock.

CLEARING RAKE FOR MINI EXCAVATORS 1 TO 6 T

	MRR 10	MRR 60
excavator	1,8 t	2-2,5 t
adapter size	SW01	SW03
teeth	3	4
tooth radius (mm)	500	700
weight (kg)	150	175

CLEARING RAKE FOR COMPACT EXCAVATORS 6 TO 12 T

	CRR 80
excavator	6,1-12 t
adapter size	SW08
teeth	4
tooth radius (mm)	850
weight (kg)	265

PALLET FORK MPG5, CPG10

Enables loads to be picked up on standard pallets due to adjustable forks.

- in various sizes for 1.8 to 2.4 t load capacity
- Lehmatic adapter or Symlock® adapter included

For an extended range of possibilities:

With Symlock® adapter can be used rotated e.g. for transport, procedure.



PALLET FORK FOR MINI EXCAVATORS 5 TO 6 T

	MPG 5
excavator	5-6 t
adapter size	SW03
width (mm)	1100
fork arms (mm)	1200 x 100 x 45
weight (kg)	251
load capacity (t)	1,8

PALLET FORK FOR COMPACT EXCAVATORS 6 TO 12 T

	CPG 10
excavator	6,1-12 t
adapter size	SW08
width (mm)	1100
fork arms (mm)	1200 x 100 x 45
weight (kg)	265
load capacity (t)	2,4



LEHNHOFF HARTSTAHL GMBH

Rungsstraße 10–15 | D-76534 Baden-Baden
post box 11 01 65 | D-76487 Baden-Baden

Tel. +49 7223 966-0
Fax +49 7223 966-149

lehnhoff.de
info@lehnhoff.de

Hotline sales: +49 7223 966-140

YOUR LOCAL DEALER: